

DIN STANDARD CONNECTIONS

# M81642/M81643

**45° METRIC  
O-RING FEMALE SWEPT ELBOW 24° CONE  
HEAVY DUTY  
DIN 20066 / ISO 12151-2**

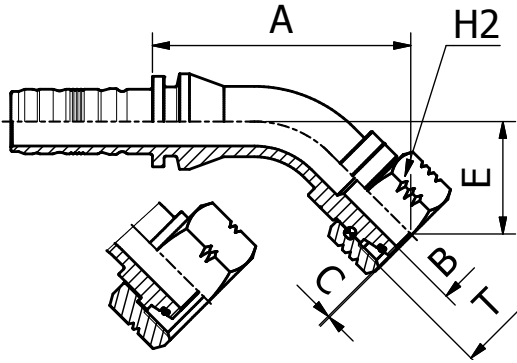

PART. REF.	HOSE BORE			Thread	Pipe	DIMENSIONS mm						
	DN	Dash	inch	T	mm	B	A	C	E	H2		
M81642-10-24	16	- 10	5/8"	M24X1.5	16.0	9.3	70.0	4.0	29.5	30.0		
M81642-10-30	16	- 10	5/8"	M 30X2	20.0	12.0	74.0	3.2	33.5	36.0		
M81643-10-36	16	- 10	5/8"	M 36X2	25.0	16.0	74.5	3.4	30.5	41.0		
M81642-12-30	19	- 12	3/4"	M 30X2	20.0	12.5	80.0	3.2	35.0	36.0		
M81643-12-36	19	- 12	3/4"	M 36X2	25.0	14.5	82.0	3.4	33.5	41.0		
M81642-16-36	25	- 16	1"	M 36X2	25.0	15.0	103.0	4.1	44.5	41.0		
M81643-16-42	25	- 16	1"	M 42X2	30.0	19.5	94.0	5.3	36.0	50.0		
M81642-20-42	31	- 20	1.1/4"	M 42X2	30.0	19.1	117.5	6.0	44.0	50.0		
M81643-20-52	31	- 20	1.1/4"	M 52X2	38.0	26.1	111.0	8.0	40.0	60.0		

241 FITTINGS

DIN STANDARD CONNECTIONS

# M81692/M81693

**90° METRIC  
O-RING FEMALE SWEPT ELBOW 24° CONE  
HEAVY DUTY  
DIN 20066 / ISO 12151-2**

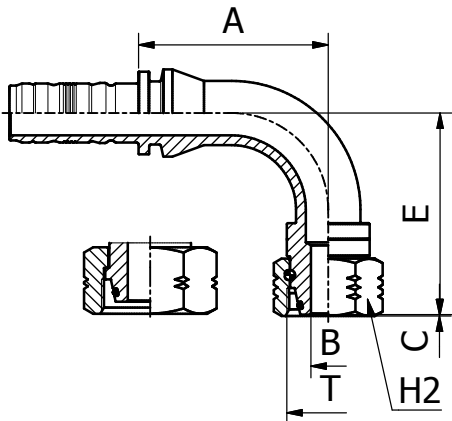

PART. REF.	HOSE BORE			Thread	Pipe	DIMENSIONS mm						
	DN	Dash	inch	T	mm	B	A	C	E	H2		
M81692-10-24	16	- 10	5/8"	M24X1.5	16.0	9.3	57.0	4.0	58.5	30.0		
M81692-10-30	16	- 10	5/8"	M 30X2	20.0	12.0	57.0	3.2	64.0	36.0		
M81693-10-36	16	- 10	5/8"	M 36X2	25.0	16.0	60.5	3.4	60.0	41.0		
M81692-12-30	19	- 12	3/4"	M 30X2	20.0	12.5	64.5	3.2	68.5	36.0		
M81693-12-36	19	- 12	3/4"	M 36X2	25.0	14.5	68.0	3.4	67.5	41.0		
M81692-16-36	25	- 16	1"	M 36X2	25.0	15.0	83.0	4.1	87.5	41.0		
M81693-16-42	25	- 16	1"	M 42X2	30.0	19.5	82.5	5.3	75.5	50.0		
M81692-20-42	31	- 20	1.1/4"	M 42X2	30.0	19.1	102.0	6.0	90.0	50.0		
M81693-20-52	31	- 20	1.1/4"	M 52X2	38.0	26.1	101.0	8.0	86.5	60.0		